

TN Type Flow Control (and Check) Valve

0.03 to 8 ℓ /min
10.5MPa

(Fine Adjustment Type With Pressure and Temperature Compensation)

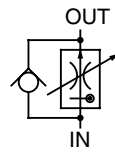

Features

- ① With a very compact, lightweight configuration, the intelligent design of this valve makes it a low-cost option.
- ② Minute flow rate control from 30cm³.
- ③ Stable control of each setting flow rate, even as pressure and fluid temperature are fluctuating.
- ④ Dial markings are proportional to flow rate for simple and accurate control flow rate adjustment.

Specifications

Model No.	Nominal Diameter (Size)	Volume control flow rate ℓ /min	Maximum Working Pressure MPa{kgf/cm ² }	Reverse Flow Rate ℓ /min	Cracking pressure MPa{kgf/cm ² }	Weight kg
(C)TN-G02-2-11 8-11	1/4	0.03 to 2 0.05 to 8	10.5{107}	35	0.1{1.0}	2.2

● Handling

- ① In the temperature range of 20°C to 60°C, flow rate fluctuation is within ±5% of the standard flow rate at 40°C.
- ② In the pressure range of 1.0 to 10.5MPa {10.2 to 107kgf/cm²}, flow rate fluctuation is within ±5% of the setting flow rate.
- ③ Note that flow rate fluctuation exceeds the rated flow rate fluctuation amount slightly in the vicinity of the minimum control flow rate, due to changes in operating temperature and hydraulic fluid viscosity.
- ④ When controlling flow rates that are less than 0.2 ℓ /min, use with a filter that does not exceed 10μm.
- ⑤ Make sure that the pressure differential between the inlet port and outlet is at least 0.6MPa {6.1kgf/cm²} at 4 ℓ /min or less, and at least 1.0MPa {10.2kgf/cm²} at 4 ℓ /min or greater.
- ⑥ The control flow rate is increased by clockwise (rightward) rotation of the adjustment handle.
- ⑦ For connection to piping, normally connect to the sub plate. Valve mounting is gasket type, using an O-ring. When a screw in connection is required, seal the gasket surface, remove the side plug, and create a screw in connection directly to the valve unit. In this case, remove all seal material affixed to the plug.
- ⑧ Use the following table for specification when a sub plate is required.

Model No	Pipe Diameter	Recommended Flow Rate ℓ /min	Weight kg
MTL-03-10	3/8	35	1.3

⑨ Bundled Accessories: Hex Socket Bolts M8 x 60 ℓ , (four)

- Note) 1.For mounting bolts, use 12T or equivalent.
2.Tightening torque is 20 to 25N·m {205 to 255kgf·cm}.

Understanding Model Numbers

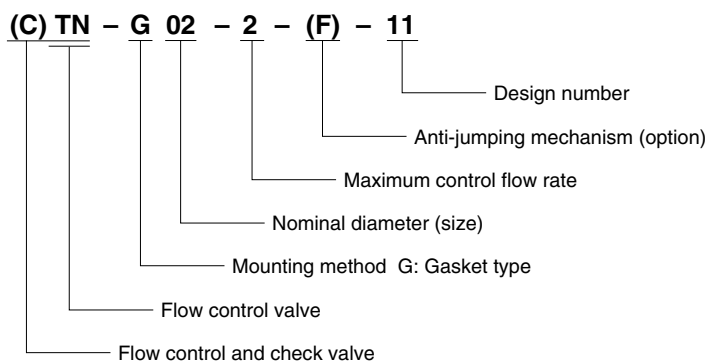

Installation Dimension Drawings

(C)TN-G02-**-11

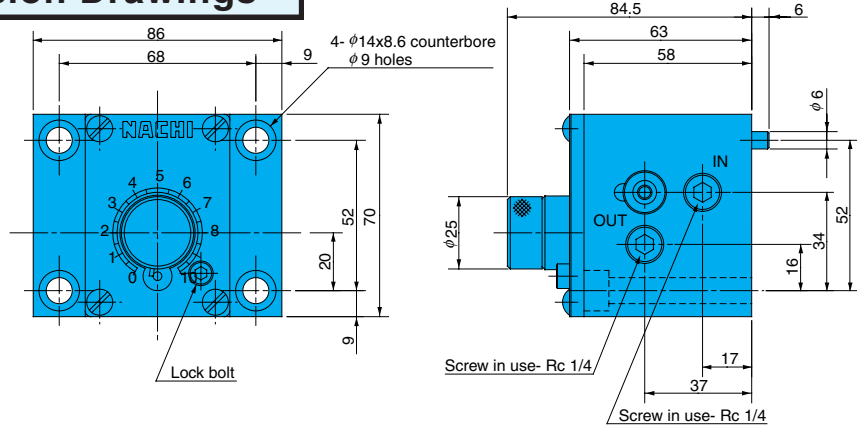

Sub Plate MTL-03-10

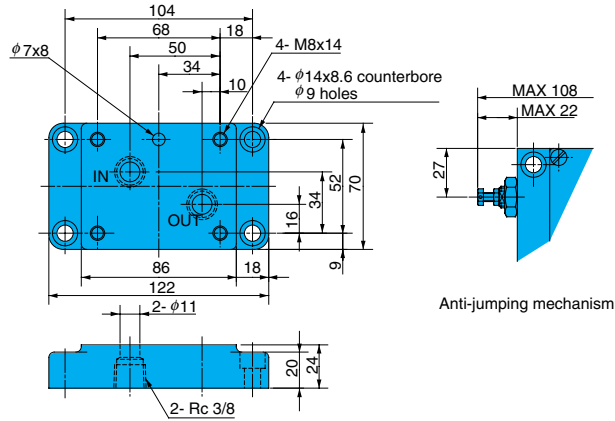

Performance Curves

Hydraulic Operating Fluid Viscosity 32mm²/s

Fluid Temperature – Control Flow Rate Characteristics

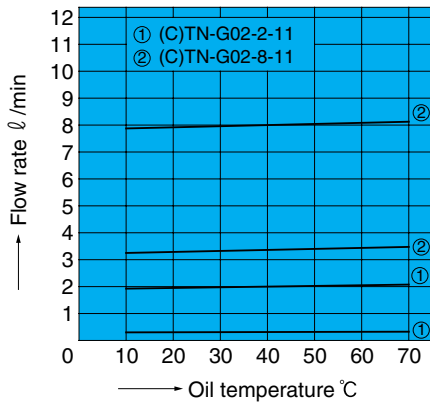

Pressure – Control Flow Rate Characteristics

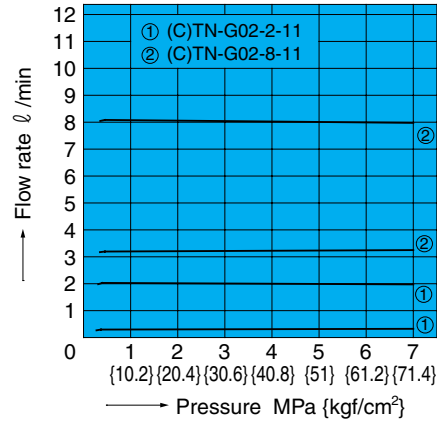

Scale – Control Flow Rate Characteristics

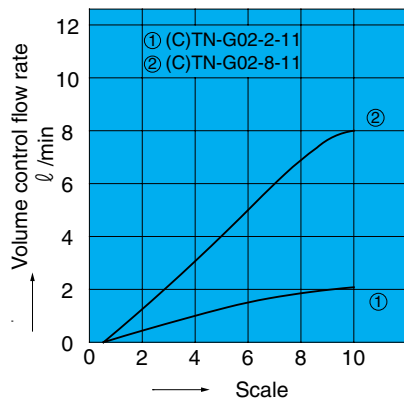

Pressure Loss Characteristics

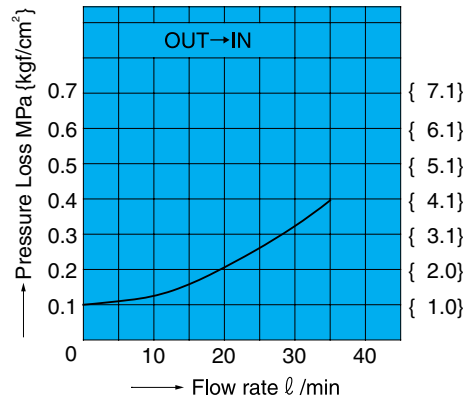

Cross-sectional Drawing

Note) O-ring 1A-** refers to JIS B2401-1A-**.

CTN-G02-*-11

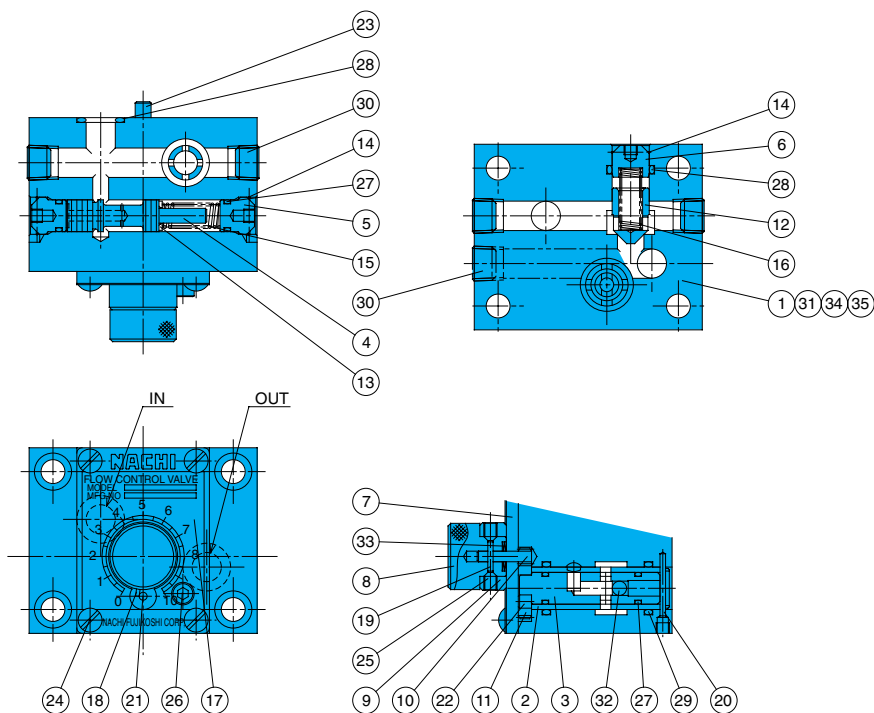

Part No.	Part Name	Part No.	Part Name	Part No.	Part Name
1	Body	13	Spacer	25	Screw
2	Sleeve	14	Snap ring	26	Screw
3	Spool	15	Spring	27	O-ring
4	Piston	16	Spring	28	O-ring
5	Plug	17	Plate	29	O-ring
6	Plug	18	Pin	30	Plug
7	Plate	19	Pin	31	Ball
8	Knob	20	Pin	32	Ball
9	Ring	21	Pin	33	Washer
10	Gear	22	Pin	34	Screw
11	Gear	23	Pin	35	Plate
12	Poppet	24	Screw		

Seal Part List (Kit Model Number FNS-G02(C))

Part No.	Part Name	TN-G02-*-11		CTN-G02-*-11	
		Part Number	Q'ty	Part Number	Q'ty
27	O-ring	IA-P9	4	IA-P9	4
28	O-ring	IA-P14	2	IA-P14	3
29	O-ring	IA-P16	2	IA-P16	2

Note) Specify C at the end of the model number for the CTN kit.

Anti-jumping mechanism (C)TN-G02-*-F-11

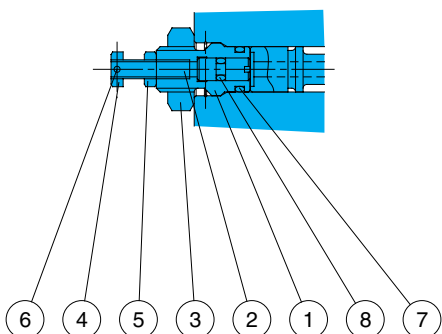

Part No.	Part Name
1	Retainer
2	Bolt
3	Nut
4	Nut
5	Nut
6	Spring pin
7	O-ring
8	O-ring

Seal Part List

Part No.	Part Name	Part Number	Q'ty
7	O-ring	IA-P9	1
8	O-ring	IA-P3	1

Note) #7 O-ring and #27 O-ring are interchangeable.

